

ACR Radiography Fluoroscopy Accreditation Phantom

The CIRS Model 903 ACR Radiography / Fluoroscopy Phantom is designed to be an integral part of the American College of Radiology (ACR) Radiography / Fluoroscopy Accreditation Program. This voluntary program provides physicians with an opportunity for a comprehensive peer review of their Radiography / Fluoroscopy facility, personnel qualifications, image quality and quality assurance programs.

The ACR Radiography / Fluoroscopy Accreditation Phantom can be used for initial QA assessment and routine monthly QA testing to help ensure patients are receiving the best possible x-ray examinations.

The CIRS Model 903 is manufactured from PMMA



Model 903

equivalent epoxy that offers the same x-ray attenuation properties as acrylic with significantly greater durability.

The overall phantom measures 25 cm wide x 25 cm long x 20.7 cm high and consists of three attenuation

plates, one test object plate and a detachable stand for easy, reproducible set-up. Test objects include high-resolution copper mesh targets from 12 – 80 lines per inch, two separate contrast-detail test objects.

Model 903 Specifications:

Radiography/Fluoroscopy Accreditation Phantom

SIDE VIEW

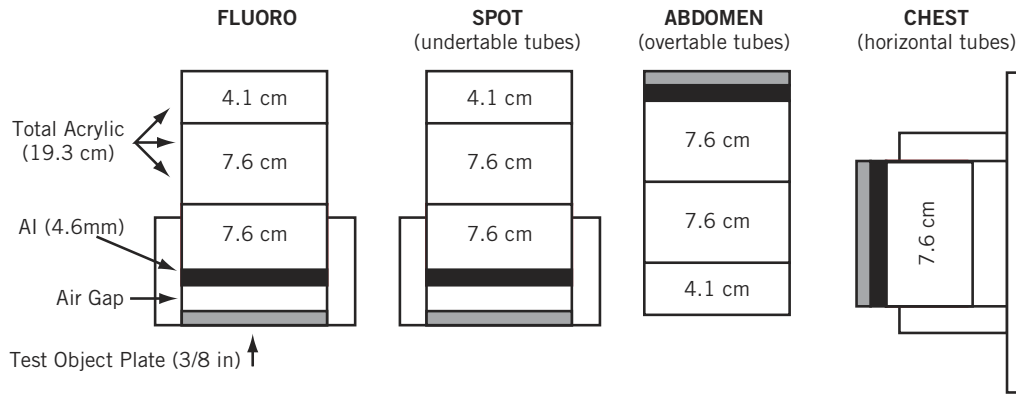

TOP VIEW

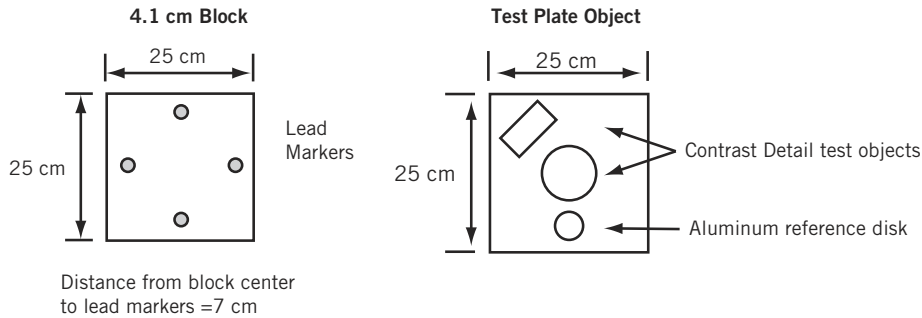

CONTRAST-DETAIL TEST OBJECT

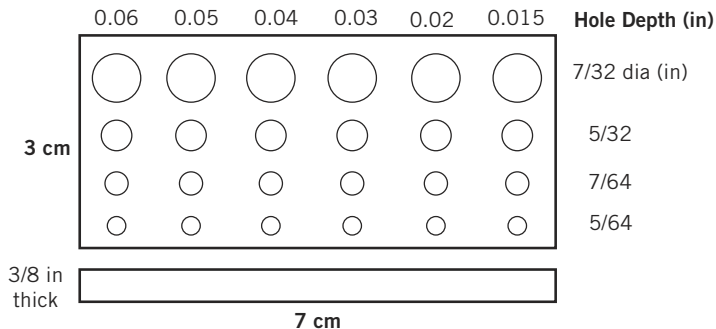

HIGH CONTRAST MESH

- LINES PER INCH
- A-80
 - B-12
 - C-16
 - D-20
 - E-24
 - F-30
 - G-40
 - H-50
 - I-60

Meshes arranged in incremental order
Lines angled at 45°

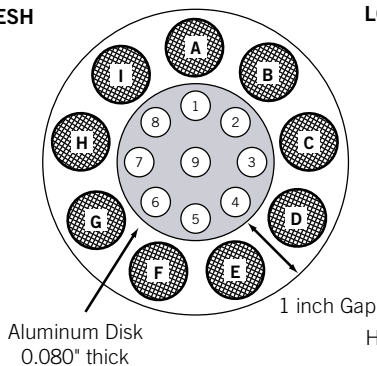

LOW CONTRAST HOLES IN ALUMINUM DISK

- HOLE DEPTHS
- 1 - 0.068
 - 2 - 0.049
 - 3 - 0.035
 - 4 - 0.025
 - 5 - 0.018
 - 6 - 0.0126
 - 7 - 0.0091
 - 8 - 0.0063
 - 9 - 0.0040

Hole Diameter = 0.375"