

# Cardiac Doppler Flow Phantom

Models ATS 523 & 523A



The Models 523 and 523A rubber based tissue mimicking Doppler flow phantoms contain four flow channels of various diameters (normally 2, 4, 6, and 8mm diameter) simulating the deep vasculature of the cardiac and abdominal vessels.

Two fixed-angled scan surfaces maintain a constant angle between the sound beam and the Doppler Test Fluid flowing through the phantom. The scan surfaces of the Model 523 are angled at 45° and 60°, permitting continuous scanning at depths ranging from 5 to 18 cm. In the Model 523A, the scan surfaces are angled at 18° and 56°, permitting continuous scanning at depths ranging from 3 to 17 cm. All ATS urethane phantoms are guaranteed for the useful life of the phantom, defined as 10 years.

## Key Tests with Models ATS 523 & 523A

- Sensitivity
- Flow Velocity
- Flow Location
- Penetration
- Uniformity

# CIRS

900 Asbury Ave • Norfolk, Virginia 23513 • USA • Tel: 757-855-2765 • [WWW.CIRSINC.COM](http://WWW.CIRSINC.COM)

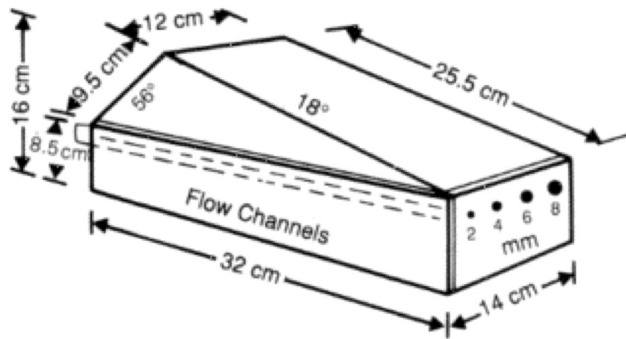

MODEL 523A

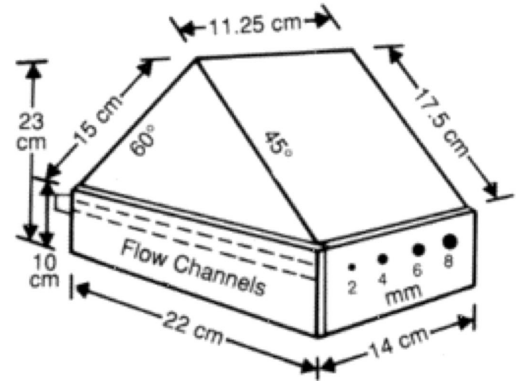

MODEL 523

SPECIFICATIONS

MODEL ATS 523

DIMENSIONS	22 x 14 x 10 cm (9" x 6" x 4")
PHANTOM WEIGHT	13 lbs. (6.1 kg)
HOUSING MATERIALS	PVC
SCAN SURFACES	4
MAXIMUM FLUID PRESSURE	15 psi (1.05 Kg/cm)
SCAN SURFACE DIMENSIONS	17.5x11.25cm @ 45° 15x11.25cm @ 60°
CONNECTORS	Stainless Steel Hose barb
TISSUE-MIMICKING MATERIAL	Urethane Rubber

MODEL ATS 523A

DIMENSIONS	32 x 14 x 8.5cm (13" x 6" x 3")
PHANTOM WEIGHT	15.2 lbs. (6.9 kg)
HOUSING MATERIALS	PVC
SCAN SURFACES	4
MAXIMUM FLUID PRESSURE	15 psi (1.05 Kg/cm)
SCAN SURFACE DIMENSIONS	25.5x12.0cm @ 18° 9.5x12.0cm @ 56°
CONNECTORS	Stainless Steel Hose barb
TISSUE-MIMICKING MATERIAL	Urethane Rubber

MODELS ATS 523 & 523A INCLUDE

QTY	COMPONENT DESCRIPTION
1	Cardiac Doppler Flow Phantom
-	10-Year Warranty
-	User Guide
-	Certificate of Compliance

URETHANE PROPERTIES

Freezing point: < -40°C  
 Melting point: Above 100° C  
 Speed of Sound: 1450 m/s ±1.0% at 23°  
 Attenuation Coefficient: 0.5 dB/cm/MHz ± 10%

523 FLOW CHANNELS

Type: Circular  
 Number of Channels: 4  
 Diameters: 2, 4, 6, 8 mm  
 Scan Surface Depths: 5.0-16.0cm @ 45°  
 Scan Surface Depths: 5.0-18.0cm @ 60°

523A FLOW CHANNELS

Type: Circular  
 Number of Channels: 4  
 Diameters: 2, 4, 6, 8 mm  
 Scan Surface Depths: 3.0-11.0cm @ 18°  
 Scan Surface Depths: 4.0-17.0cm @ 56°

