

CBCT Electron Density & Image Quality Phantom System

Model 062M, 062MA & 062MQA



MINIMIZE DOSE • INCREASE IMAGE QUALITY • ENHANCE OUTCOMES

PRODUCT GUIDE

900 Asbury Ave • Norfolk, Virginia 23513 • USA
Tel: 800.617.1177 • 757.855.2765 • Fax: 757.857.0523

WWW.CIRSINC.COM

CIRS

Tissue Simulation & Phantom Technology

Overview

The CBCT Electron Density & Image Quality Phantom System integrates three phantoms in one highly functional and ergonomic package. The phantom system can be configured as:

Model 062M Electron Density Phantom

Model 062MA CBCT Electron Density Phantom

Model 062QA-35 Image Quality Phantom

Model 062MQA CBCT Electron Density and Image Quality Phantom

The “M” within the model numbers stands for “modular” and is used to suggest that any of these phantoms can be used separately or in combination with extra parts to form a different phantom.

Model 062M Electron Density Phantom configuration is composed of Head and Body Electron Density sections and tissue-equivalent electron density plugs.

Model 062MA CBCT Electron Density Phantom configuration is an extended version of the CIRS Model 062M Electron Density Phantom specially designed for Cone Beam KV and MV CT imaging systems. It was designed in collaboration with Dr. Peter H. Cossmann, PhD to provide a reliable tool for CT number to electron density calibration in volumetric imaging. Reliable CT electron density calibration curves help enable treatment plan adaptation directly from Cone Beam CT (CBCT) data. The phantom can also accommodate any ion chamber for dose measurements and validation of heterogeneity correction based on the corrected CT calibration curve. Customers who currently own the Model 062M can upgrade their system to the Model 062MA by purchasing an upgrade kit (Model 062MA-35).

Model 062MQA CBCT Electron Density & Image Quality Phantom configuration adds the Model 062QA-35 Image Quality Phantom to the 062MA CBCT Electron Density Phantom configuration. The Image Quality Phantom presents a series of features designed to perform the entire set of Image QA tests for Computed Tomography recommended in Report #1 of the Task Group as approved by the American Association of Physicists in medicine. This phantom is also compliant with TG-142 (Table VI) Report: QA of Medical Accelerators.

The size of the 062MA and 062MQA covers geometries for imager dimensions of up to 40 cm x 40 cm. They are made of Plastic Water®-LR (15 keV - 8 MeV) and contain a set of tissue equivalent electron density plugs for calibration. Additional interchangeable slabs along with the phantom's support system allow for off-axis repositioning of the Electron Density section and CBCT Image Quality Phantom with an increment of 1.25 cm.

While the design intent of both the Model 062MA and 062MQA is to account for the specific geometry of volumetric imaging equipment, these configurations are also suitable for axial/helical CT equipment and provide the user with an imaging volume that closely resembles an average male torso.

REFERENCES:

PH Cossmann, A Stuessi, C von Briel, Characterisation of a Linac Cone-Beam-CT Option: What Is the Future Potential for Treatment Planning? SU-GG-T-536, Medical Physics, Vol. 35, No. 6, June 2008.

PH Cossmann, U Gneveckow, C von Briel Characterisation of a Linac Cone-Beam-CT Option: What Is the Future Potential for Treatment Planning? SSK17-04, RSNA Scientific Assembly and Annual Meeting Program 2008, p. 546.

PH Cossmann, U. Gneveckow Characterisation of a Linac Cone-Beam-CT Option: What Is the Future Potential for Treatment Planning? Medical Physics (submitted).

PH Cossmann, V. Varchena A novel phantom design for the electron density calibration of a linac CBCT option, Zeitschrift fuer Medizinische Physik (submitted).



ICRU Report No.44, January 1989, p.22.

CAPABILITIES

- Perform tests per AAPM TG-1 and TG-142
- Obtain maximum CTU information from a single scan
- Calibrate with optional high-density references
- Perform dose verification with ionization chambers
- Evaluate effects of beam hardening on HU values & Image quality
- Accommodate ion chambers for dose measurements and validation of heterogeneity corrections

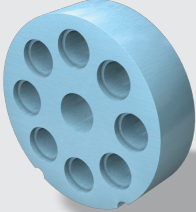
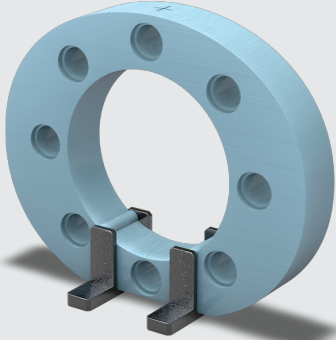
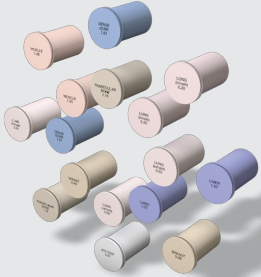
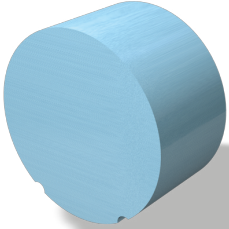
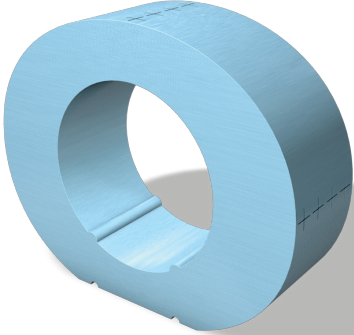
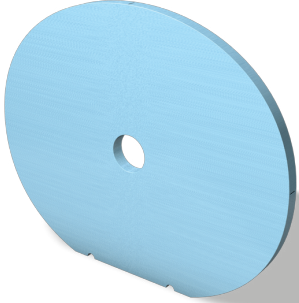
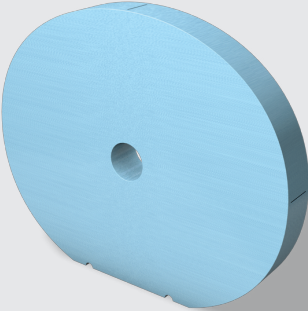
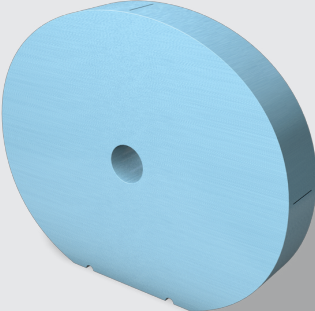
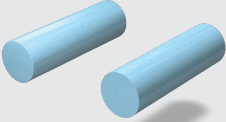

Standard System Components

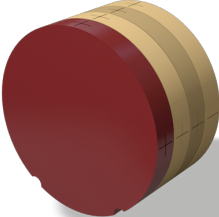
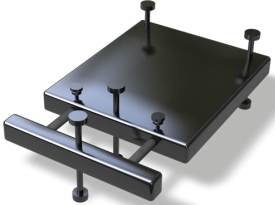
		
<p>1 Electron Density Phantom Head Insert 062MA-01</p>	<p>2 Electron Density Phantom Body w/feet 062MA-02</p>	<p>3 Electron Density Phantom Plugs</p>
		
<p>4 CBCT Electron Density Phantom Annulus Insert (100 mm thick) 062MA-37</p>	<p>5 CBCT Electron Density Phantom Annulus (100 mm thick) 062MA-36</p>	<p>6 CBCT Electron Density Phantom Bolus Section (12.5 mm thick) 062MA-33</p>
		
<p>7 CBCT Electron Density Phantom Bolus Section (37.5 mm thick) 062MA-34</p>	<p>8 CBCT Electron Density Phantom Bolus Section (50 mm thick) 062MA-24</p>	<p>9 Background Insert (2 Units) 062MA-32</p>
		
<p>10 062MA & 062MQA Holder & Stand 062MA-30</p>	<p>11 CT Image Quality Phantom 062MQA-50</p>	<p>12 CT Image Quality Phantom Holder & Stand 062MQA-30</p>

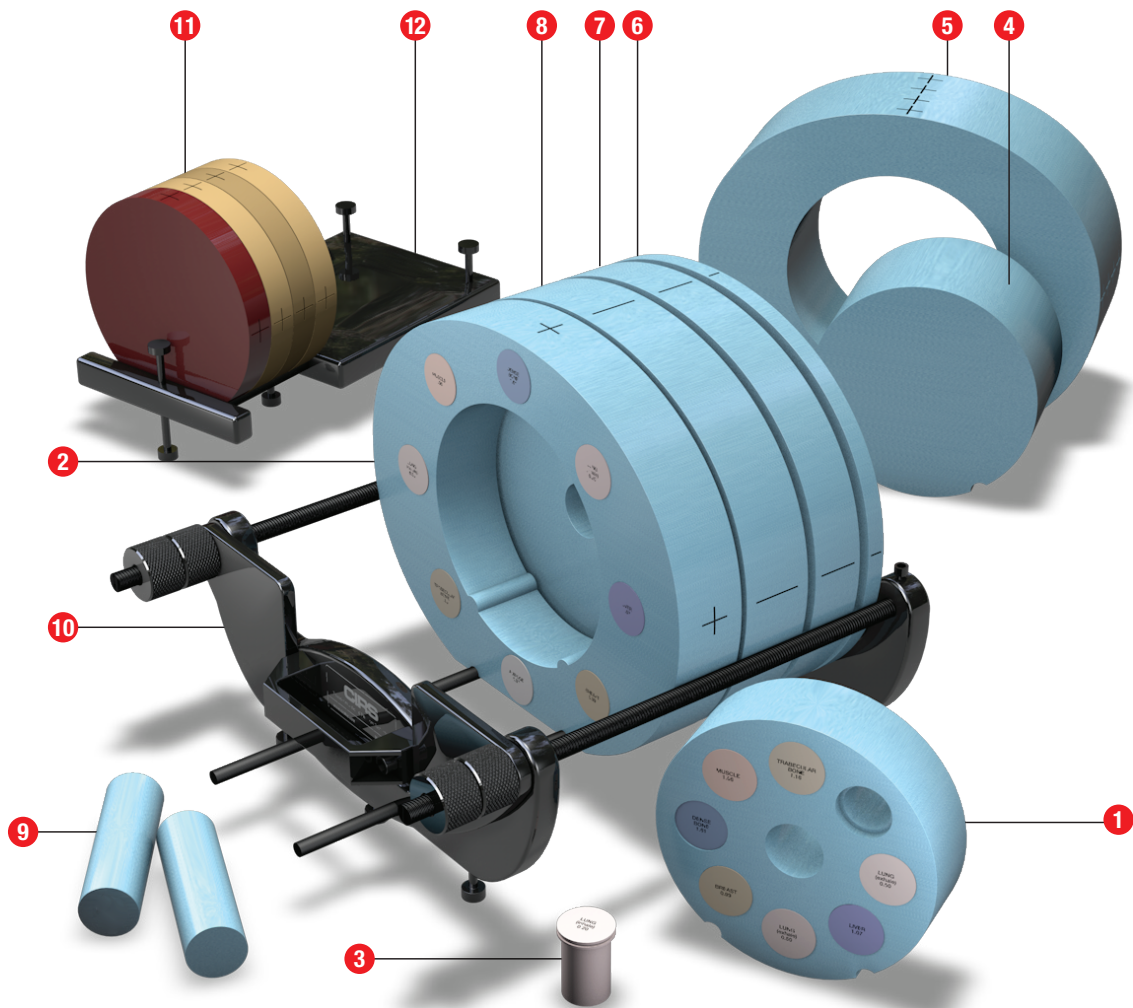

CBCT ELECTRON DENSITY AND IMAGE QUALITY PHANTOM
 Model 062MQA
 Components 1-12

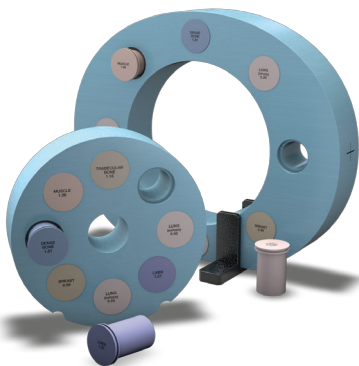

ELECTRON DENSITY PHANTOM
 Model 062M
 Components 1-3

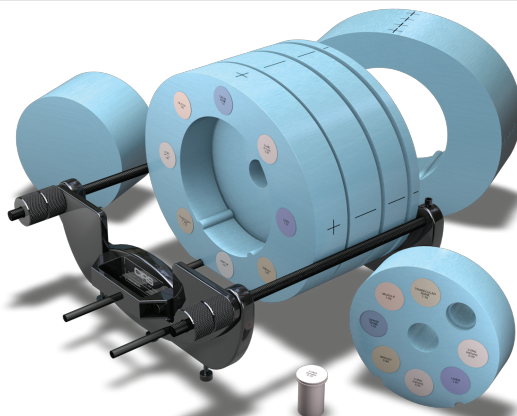

CBCT ELECTRON DENSITY PHANTOM
 Model 062MA
 Components 1-10

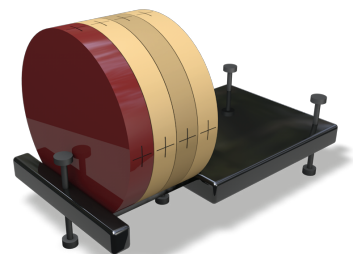

IMAGE QUALITY PHANTOM
 Model 062QA-35
 Components 11-12

Electron Density Phantom

MODEL 062M

The Electron Density Phantom, Model 062M, is used to account for tissue heterogeneity in radiotherapy treatment planning. The phantom is used with a CT scanner to provide precise correlation between electron density of tissues and their CT number in Hounsfield units (HU).

The Model 062M consists of two nested disks made from Plastic Water®-LR. They can represent both head and abdomen configurations. Nine different tissue equivalent electron density plugs can be positioned at 17 different locations within the scan field. Included is a water vial plug that can be filled with any fluid. Optional distance marker plugs enable quick assessment of the CT scanner's distance measurement accuracy.

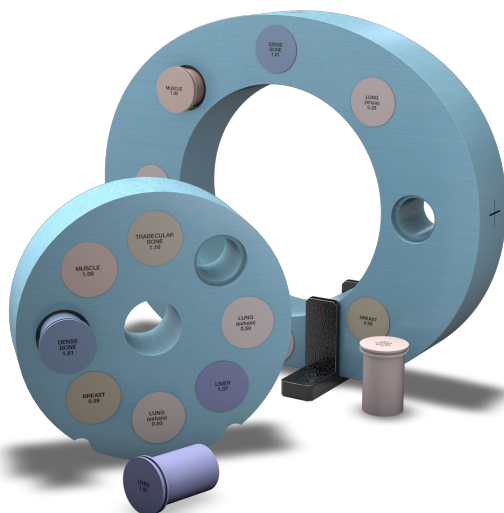

FEATURES:

- Evaluate CT scan data
- Correct for inhomogeneities
- Document relationship between CT number and tissue electron density
- Simulate indicated tissue within the diagnostic and therapeutic energy range
- Quick assessment of distance registration (optional)

SPECIFICATIONS MODEL 062M - TABLE 1

OVERALL DIMENSIONS:	Electron Density Head Insert: Ø 180 mm x 50 mm (Ø x D) Electron Density Body without Head Insert: 330 mm x 270 mm x 50 mm (W x H x D) Electron Density Plugs: Ø 30 mm X 50mm (Ø X L)
WEIGHT:	Electron Density Head Insert: ≈ 0.950 kg (2 lb) Electron Density Body without Head Insert: ≈ 2.1 kg (4.7 lb)
MATERIALS:	Water and Tissue Equivalent Epoxy Resins

QTY	PART NO.	DESCRIPTION	*PHYSICAL DENSITY, g/cc	ELECTRON DENSITY, x 10 ²³ electrons/cc	RED (RELATIVE TO H ₂ O)
1	062MA-01	Electron Density Head Insert	1.029	3.333	0.998
1	062MA-02	Electron Density Body without Head Insert	1.029	3.333	0.998
2	062A-04	Lung (Inhale) Equivalent Electron Density Plug	0.205	0.668	0.200
2	062A-05	Lung (Exhale) Equivalent Electron Density Plug	0.507	1.658	0.496
2	062A-06	Breast (50% Gland / 50% Adipose) Equivalent Electron Density Plug	0.99	3.261	0.976
2	062A-08	Solid Trabecular Bone (200 mg/cc HA) Equivalent Electron Density Plug	1.16	3.730	1.117
2	062A-09	Liver Equivalent Electron Density Plug	1.07	3.516	1.052
2	062A-10	Muscle Equivalent Electron Density Plug	1.06	3.483	1.043
2	062A-11	Adipose Equivalent Electron Density Plug	0.96	3.171	0.949
2	062A-15	Solid Dense Bone (800 mg/cc HA) Equivalent Electron Density Plug	1.53	4.862	1.456
1	062A-27	Solid Dense Bone (1250 mg/cc HA) Equivalent Electron Density Plug	1.82	5.663	1.695
1	062MA-39	Water-fillable Electron Density Plug, Ø 1" removable vial inside (Real water data provided)	1.00	3.340	1.000
1	062M-30	Set of 2 Feet for Model 062M			
1	062M-40	Soft Carry Case for Model 062M			

* Physical Density - The actual physical density of the insert can vary within ± 1% of the manufacturing target density.

Note: CIRS strongly recommends that the user inputs the electron density whenever prompted for material data by the TPS.

CBCT Electron Density Phantom

MODEL 062MA

The Cone Beam (CBCT) Electron Density Phantom is an extended version of the CIRS Model 062M Electron Density Phantom, specifically designed for Cone Beam CT Imaging systems. Preliminary data shows that there may be differences between the HU readings for Diagnostic CT and Cone Beam CT. The geometry of the Cone Beam CT requires additional material and suggests that off-central axis measurements should be taken.

The phantom is a valuable tool for CT number to electron density calibration in volumetric imaging. Reliable CT calibration curves help enable treatment plan adaptation directly from Cone Beam CT data. Additionally, the phantom can accommodate any ion chamber for dose measurements and validation of tissue heterogeneity correction based on the corrected CT calibration curve.

The Model 062MA CBCT Electron Density Phantom's size covers geometries for imagers with dimensions up to 40 cm x 40 cm. It is made of Plastic Water®-LR and contains the same set of tissue equivalent electron density inserts as the standard Model 062M. Additional interchangeable slabs allow for repositioning of the electron density section off axis.

Customers who currently own the Model 062M can upgrade their system to the Model 062MA by purchasing an upgrade kit (Model 062MA-35).

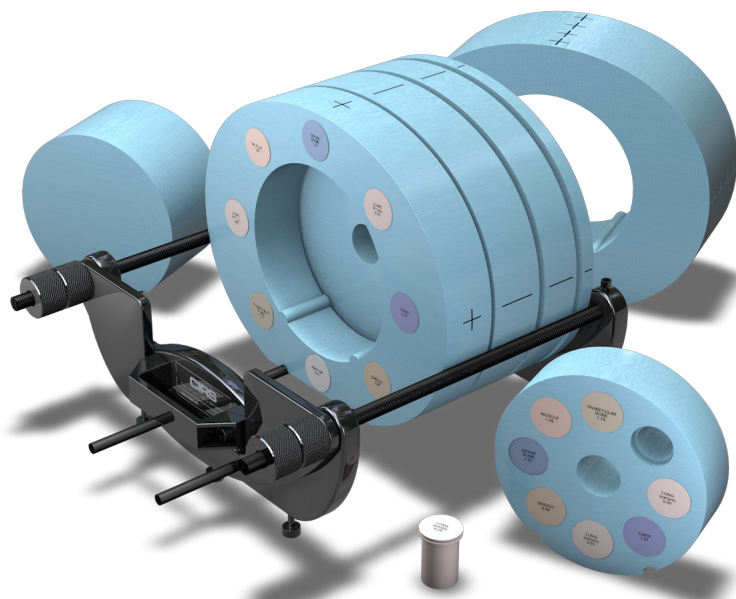

FEATURES:

- Evaluate CT scan data
- Correct for inhomogeneities
- Document relationship between CT number and tissue electron density
- Simulate indicated tissue within the diagnostic and therapeutic energy range
- Quick assessment of distance registration (optional)

SPECIFICATIONS MODEL 062MA - TABLE 2

OVERALL DIMENSIONS:	330 mm x 270 mm x 250 mm (W x H x D)				
WEIGHT:	≈ 18 kg (40 lb)				
MATERIALS:	Water and Tissue Equivalent Epoxy Resins				
QTY	PART NO.	DESCRIPTION	*PHYSICAL DENSITY, g/cc	ELECTRON DENSITY, x 10 ²³ electrons/cc	RED (RELATIVE TO H ₂ O)
1	062M	Electron Density Phantom - All standard parts (Table 1)			
1	062MA-24	50 mm Thick Bolus Slab	1.029	3.333	0.998
1	062MA-33	12.5 mm Thick Bolus Slab	1.029	3.333	0.998
1	062MA-34	37.5 mm Thick Bolus Slab	1.029	3.333	0.998
1	062MA-36	CBCT Electron Density Phantom - Annulus (100 mm Thick)	1.029	3.333	0.998
1	062MA-37	CBCT Electron Density Phantom - Annulus Solid insert (100 mm Thick)	1.029	3.333	0.998
2	062MA-32	100 mm L x Ø 30 mm Background Equivalent Plug	1.029	3.333	0.998
1	062MA-30	Holder/Support set for Model 062MA & 062MQA			
1	062MA-40	Soft Carry Case for Model 062MA			

* Physical Density - The actual physical density of the insert can vary within ± 1% of the manufacturing target density.

Note: CIRS strongly recommends that the user inputs the electron density whenever prompted for material data by the TPS.

PURCHASED SEPARATELY MODEL 062MA

1	062MA-14-CV†	Water Equivalent Chamber Rod with Cavity for Ion Chamber	1.029	3.333	0.998
---	--------------	--	-------	-------	-------

† Purchased separately. Refer to CIRS cavity and Plug code list for available Ion Chamber Cavities. If the ion chamber cavity is not specified by customer, phantom is supplied with Part No. 062MA-14-CV50-1 that accommodates a Farmer type ion chamber. TLDs and Film available upon special request.

CBCT Electron Density & Image Quality Phantom

MODEL 062MQA

The Model 062MQA phantom provides a comprehensive tool that can be used for both electron density calibration and image quality assessment of Cone Beam CT systems integrated in radiation therapy devices. The electron calibration function of the phantom enhances the outcome of adaptive radiation therapy while the image quality features address the fine balance between optimizing image quality and minimizing radiation dose.

The 062MQA CBCT Electron Density & Image Quality Phantom incorporates 3 phantoms:

1. Electron Density Phantom (50 mm thick)
2. CBCT Phantom which is used with the Electron Density Phantom
3. CT Image Quality phantom (See pages 10-11)

The 100 mm thick body section has a central hole that receives the CT Image Quality Phantom. Each Bolus slab is drilled to accommodate an ion chamber insert and allow for ion chamber measurements regardless of the position of the Image Quality Insert. The thicknesses of the sections were selected to allow for positioning of any of the layers containing the Image Quality features in the central axis of the beam. Also, sections of different thicknesses decrease the increment with which the electron density section can be offset from the central axis.

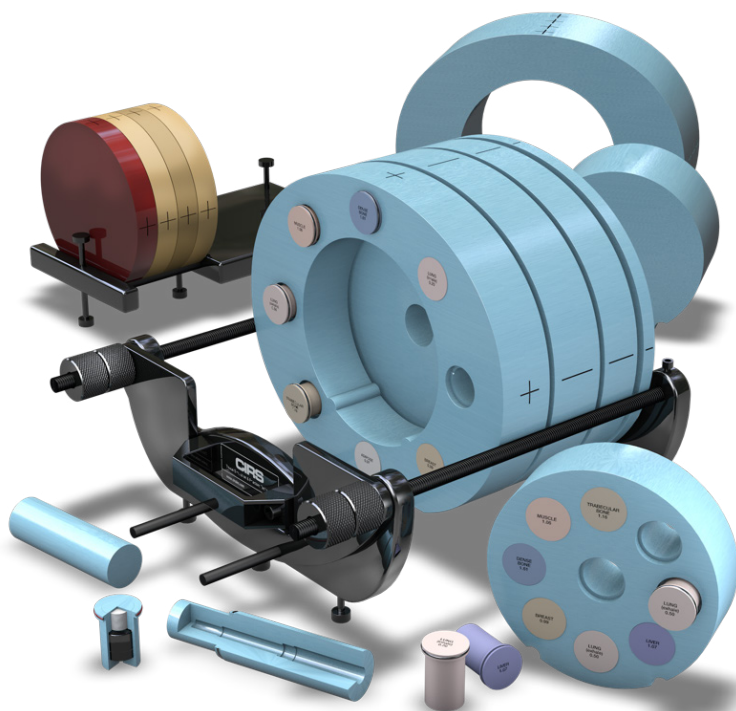

FEATURES:

- Perform all CT Image QA tests for AAPM TG Report #1
- Perform dose measurements using Ionization chambers
- Calibrate Electron Density in multi-slice CT and Cone Beam CT
- Perform central axis and off-set measurements
- Position simulated tissue materials in CT & CBCT energy range at 17 different locations
- Optimized for volumetric imaging
- Quick positioning and customized loading configurations

SPECIFICATIONS MODEL 062MQA - TABLE 3

	PART NO.	DESCRIPTION
1	062MA	Cone Beam (CBCT) Electron Density Phantom - All standard parts (Table 2)
1	062QA-35	CT Image Quality Phantom - All standard parts (Table 5, page 11)

Optional Accessories

MODEL 062M, 062MA & 062MQA

TABLE 4

PART NO.	DESCRIPTION	*PHYSICAL DENSITY, g/cc	ELECTRON DENSITY, x 10 ²³ electrons/cc	RED (RELATIVE TO H ₂ O)
062MA-07**	800 mg/cc HA in Water Equivalent - Core Insert	1.53	4.862	1.456
062MA-12**	Titanium Rod Core Insert	4.51	12.475	3.735
062MA-13	Distance Marker Insert	1.029	3.333	0.998
062MA-14-CV†	Water Equivalent Chamber Rod with Cavity for Ion Chamber	1.029	3.333	0.998
062MA-16	Water Equivalent Insert	1.029	3.333	0.998
062MA-17**	1000 mg/cc HA in Water Equivalent - Core Insert	1.660	5.243	1.570
062MA-18**	1250 mg/cc HA in Water Equivalent - Core Insert	1.82	5.663	1.695
062MA-19**	ICRU Cortical Bone Equivalent Core Insert***	1.91	5.915	1.771
062MA-20**	1500 mg/cc HA in Water Equivalent - Core Insert	1.99	6.134	1.837
062MA-21**	1750 mg/cc HA in Water Equivalent - Core Insert	2.15	6.600	1.976
062A-26	Solid Dense Bone (1000 mg/cc HA) Equivalent Electron Density Plug	1.66	5.243	1.570
062A-28	Solid Dense Bone (1500 mg/cc HA) Equivalent Electron Density Plug	1.99	6.134	1.837
062A-29	Solid Dense Bone (1750 mg/cc HA) Equivalent Electron Density Plug	2.15	6.600	1.976
062MA-41	Water Equivalent Material Surrounding 6.4mm Diameter Stainless Steel (Alloy 20) Rod Core Electron	8.03	23.101	6.917
062MA-42	Water Equivalent Material Surrounding 6.4mm Diameter Aluminum Rod Core Electron Density Plug	2.70	8.008	2.398

* Physical Density - The actual physical density of the insert can vary within ± 1% of the manufacturing target density.

Note: CIRS strongly recommends that the user inputs the electron density whenever prompted for material data by the TPS.

** These inserts have a standard Ø D of 30 mm and contain a 10 mm diameter core of the indicated reference surrounded by H₂O-equivalent background. The titanium reference has a unique diameter of 6.35 mm.

*** CIRS Cortical bone reference is based on ICRU Report No.44, and represents ≈12.2% H₂O, 24.6% protein, 58% mineral (assumed to be Calcium Hydroxyapatite (HA)), and 5.2% monosaccharides. CIRS further offers a series of mineral density references that mimic various HA concentrations in a pure water-equivalent epoxy background matrix.

† Purchased separately. Refer to CIRS cavity and Plug code list for available Ion Chamber Cavities. If the ion chamber cavity is not specified by customer, phantom is supplied with Part No. 062MA-14-CV50-1 that accommodates a Farmer type ion chamber. TLDs and Film available upon special request.

CT Image Quality Phantom

MODEL 062QA-35

The purpose of image quality measurements is to quantify various image quality indicators for 3D images taken from a selection of image acquisition and reconstruction settings representative of clinical practices. Assessment of the image quality parameters over time can show trends in variation of said parameters helping the user to decide whether or not recalibrations of the imaging system are necessary.

The Image Quality Phantom (062MQA-50) is composed of four layers: Uniformity, CT number Linearity/Slice Thickness, Low Contrast/Magnification, and Spatial Resolution

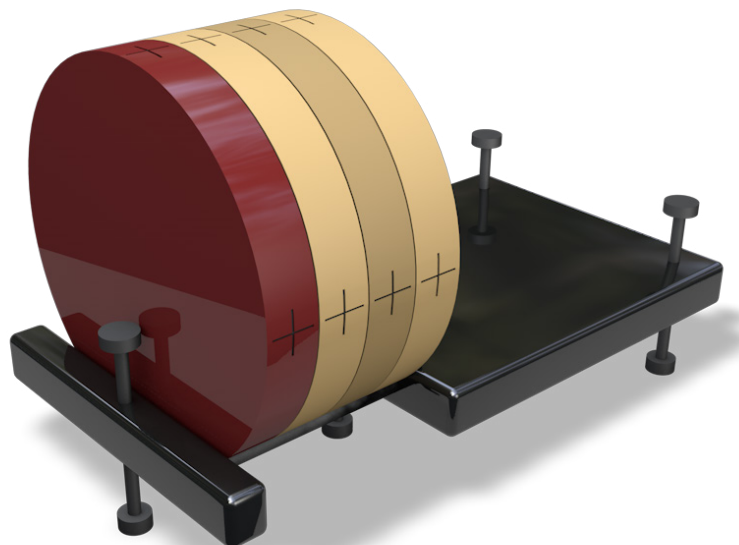

UNIFORMITY LAYER

The Uniformity Layer is designed to measure the system's ability to produce uniform images across the field of view of an object with highly homogeneous physical properties in all directions.

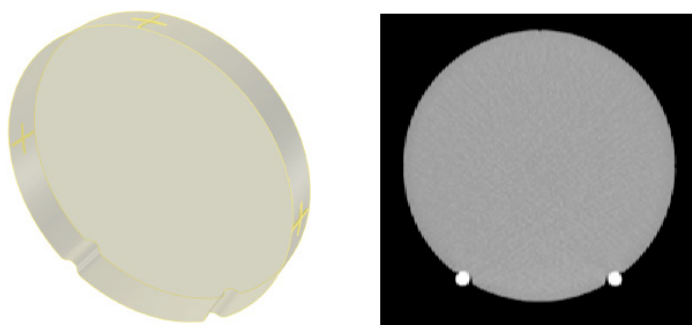

BACKGROUND:	Plastic Water®-LR
DIMENSIONS:	Ø 180 mm x 25 mm thickness

CT NUMBER LINEARITY/SLICE THICKNESS LAYER

The CT Number Linearity/Slice Thickness Layer determines Contrast-to-Noise Ratio (CNR), Hounsfield number accuracy and Slice Thickness Sensitivity.

Six rods made of different plastics are used to measure the CNR and Hounsfield number accuracy. Three angled air channels arranged in an equilateral triangle can be used to assess the Slice thickness sensitivity.

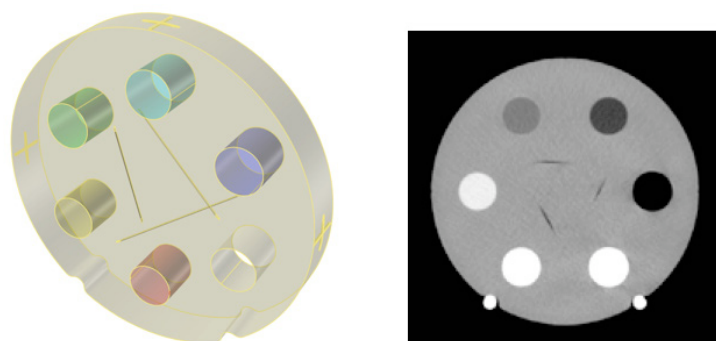

BACKGROUND:	Plastic Water®-LR
CT NUMBER LINEARITY:	Six Ø 25.4 mm (1") x 25 mm long rods made of Air, Low Density Polyethylene (LDPE), Polystyrene, Acrylic, Delrin (Acetal), Teflon
SLICE THICKNESS:	Three Ø 0.8 mm x 73.1 mm long air channel ramps placed at 20° with respect to the transversal plane arranged in an equilateral triangle
DIMENSIONS:	Ø 180 mm x 25 mm thickness

LOW CONTRAST/MAGNIFICATION LAYER

The Low Contrast Layer assesses the system's ability to detect small differences in contrast. It contains three sets of low contrast rods with linear attenuation differences of 0.5%, 1% and 2% relative to the background material. The diameters of the low contrast rods were chosen so as to provide a 0.5 ratio between two adjacent rods by cross section and volume.

Additional layer features evaluate the magnification on the orthogonal axes of the transversal image and provide input for calculation of Point Spread Function and subsequent calculation of Modulation Transfer Function.

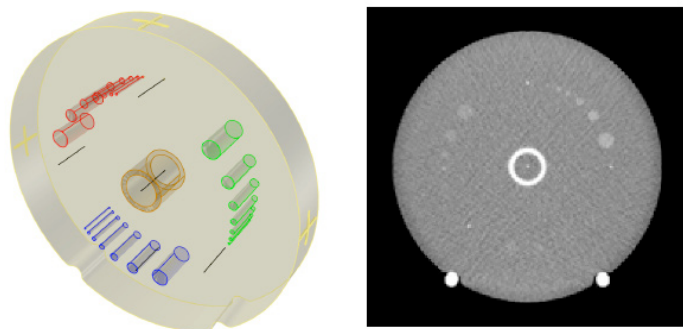

BACKGROUND:	Plastic Water®-LR
LOW CONTRAST:	3 sets of targets Ø 10, 7, 5, 3.5, 2.5, 1.8, 1.2 mm x 25 mm long with attenuation differences of 0.5%, 1% and 2% relative to the background
MAGNIFICATION:	Four Ø 0.050 mm x 25 mm long Tungsten wires which show on slices as four points, one at the center and three on a circle R55 mm at 0°, 90° and 225° or 0°, 135° and 270° (depending on scan orientation) going clockwise starting at 12 o'clock.
ALIGNMENT:	Ø Exterior 25.4 mm (1") x 25 mm long Delrin tube
DIMENSIONS:	Ø 180 mm x 25 mm thickness

SPATIAL RESOLUTION LAYER

The Spatial Resolution Layer is designed to evaluate the spatial resolution of IGRT systems. Line pair patterns from 1 lp/cm to 16 lp/cm are embedded in the background. In order to minimize artifacts, each line pair pattern is made from a material with ≈ 350 HU greater than the background attenuation. The line pair patterns are 3D patterns, 12 mm in height along the longitudinal axis of the CT Image Quality Phantom. The spatial resolution targets are arranged in a circular pattern.

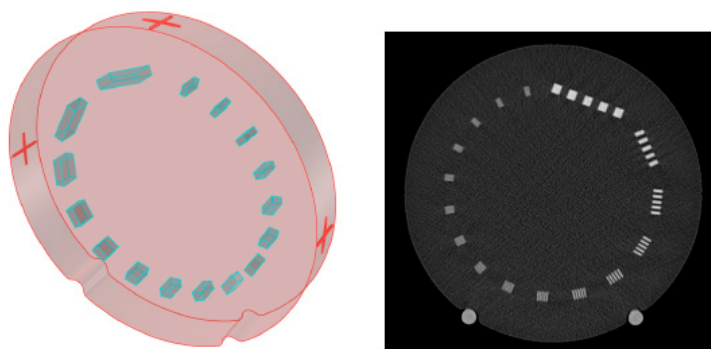

BACKGROUND:	CIRS proprietary epoxy formulation (attenuation ≈ 70 HU)
LINE PAIRS PATTERNS:	From 1 lp/cm to 16 lp/cm (attenuation ≈ 420 HU; (a contrast that is observed in angiography imaging), embedded in the background
DIMENSIONS:	Ø 180 mm x 25 mm thickness

SPECIFICATIONS MODEL 062QA-35 - TABLE 5

OVERALL DIMENSIONS:	Ø 180 mm x 100 mm (Ø x D)
WEIGHT:	≈ 2.5 kg (5.6 lb)
MATERIALS:	Water and Tissue Equivalent Epoxy Resins, Engineered Plastics

	PART NO.	DESCRIPTION	*PHYSICAL DENSITY, g/cc	ELECTRON DENSITY, x 10 ²³ electrons/cc	RED (RELATIVE TO H ₂ O)
1	062MQA-50	CT Image Quality Phantom			
		Background (Uniformity, Low Contrast/Magnification, CT Number/Slice Thickness layer)	1.029	3.333	0.998
		Background (Spatial Resolution layer)	1.11	3.641	1.090
1	062MQA-30	Holder for 062MQA-50 CT Image Quality Phantom (assembled)			
1	062MQA-40	Soft Carry Case for 062MQA-50 CT Image Phantom and 062MQA-30 Holder			

* Physical Density - The actual physical density of the insert can vary within $\pm 1\%$ of the manufacturing target density.

Note: CIRS strongly recommends that the user inputs the electron density whenever prompted for material data by the TPS.

Positioning Options

CBCT ELECTRON DENSITY & IMAGE QUALITY PHANTOM SYSTEM SETUPS

The CBCT Electron Density & Image Quality Phantom System allows users to customize the phantom setup according to their specific testing needs. Images below show different positioning arrangements of sections, which allow for off-axis Dosimetry measurements, Electron Density off-axis measurements, and axial positioning of each layer of the CBCT Image Quality Phantom (062MQA-50). The illustrations below demonstrate configurations with the 062MQA-50 inside the bolus (additional configurations shown on pages 14 and 15).

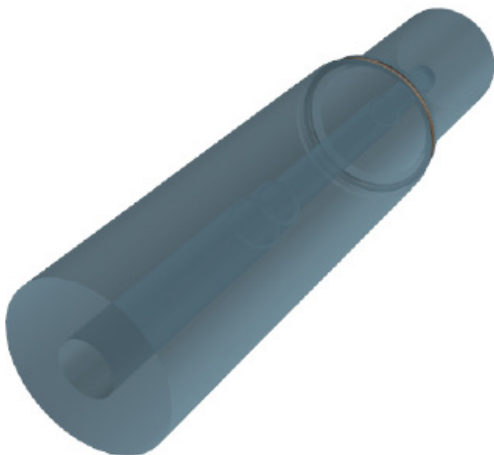
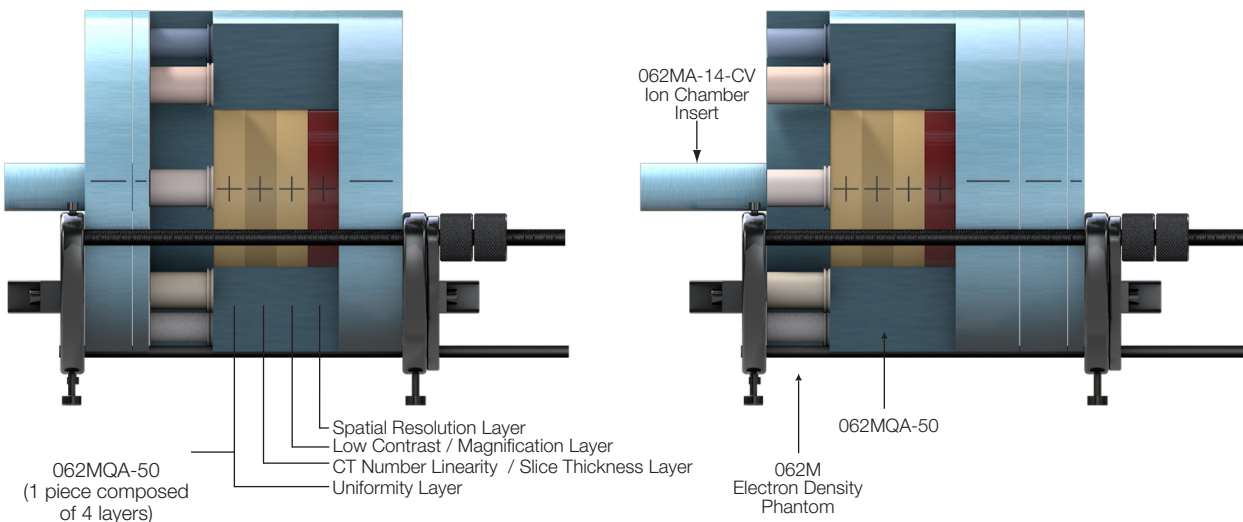
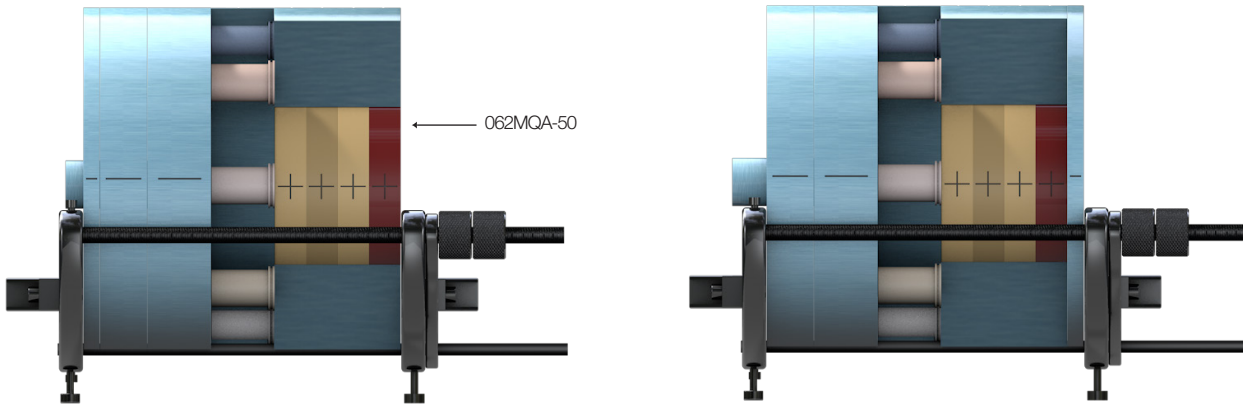

062MA-14-CV Ion Chamber Insert

Positioning Options

DOSIMETRY ARRANGEMENTS

Both 062MA CBCT Electron Density Phantom and 062MQA CBCT Electron Density & Image Quality Phantom are designed to allow for dosimetry measurements in the central location of the Electron Density Head section. Dosimetry measurements can also be taken from any location in the 062M by exchanging the Ion Chamber insert with any of the Electron Density plugs, as shown in the image on the lower right. This configuration will only work when the CBCT Electron Density Body with Head Insert is positioned at one end of the phantom.

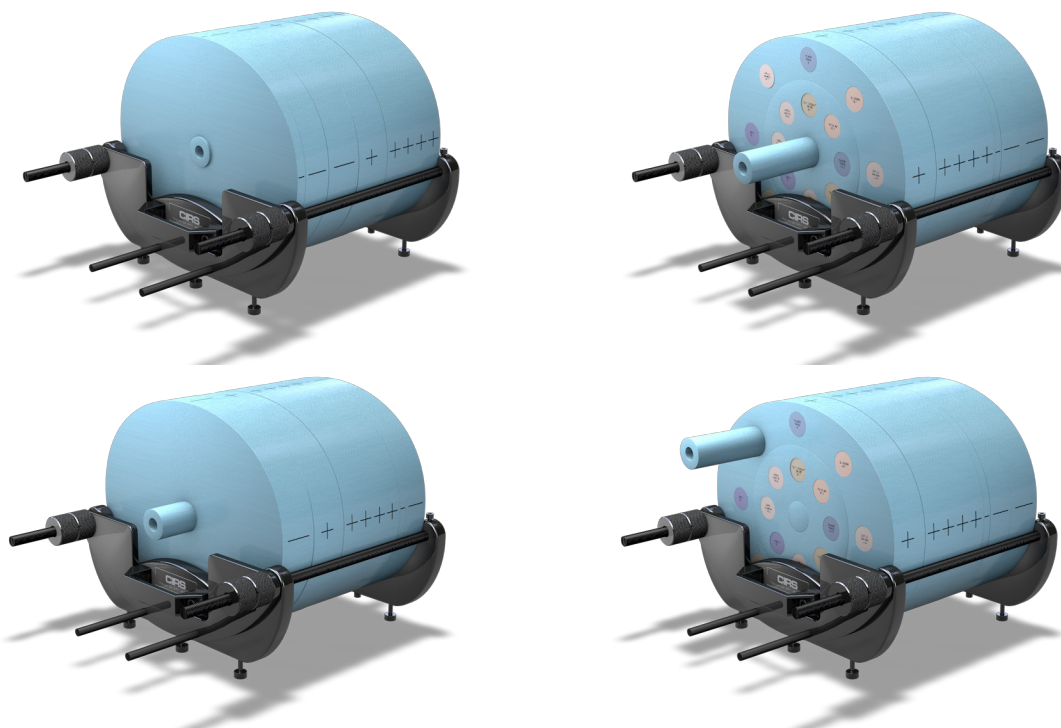

When the Ion Chamber insert is not in use, one or both $\text{\O} 30 \text{ mm} \times 100 \text{ mm}$ Background Equivalent Inserts can be placed in the central hole of bolus sections.

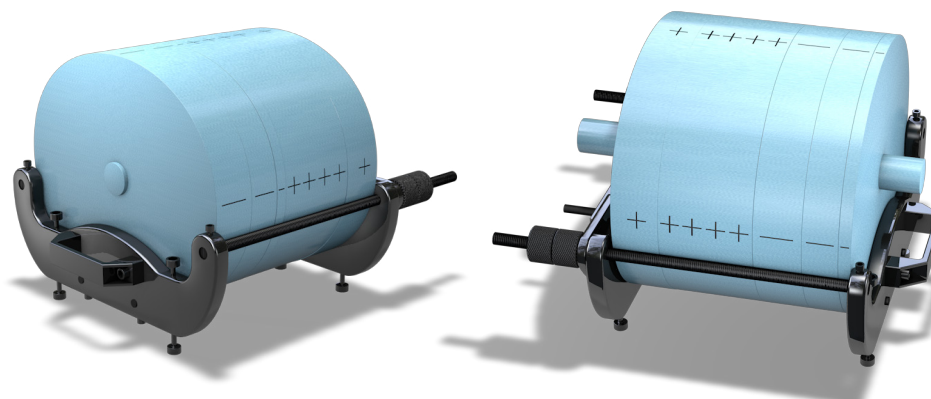

Positioning Options

MODEL 062MQA "IN-AIR" SETUP

In addition to configurations which place the CBCT Image Quality Phantom inside the bolus section (page 12), the modular system allows for "in-air" measurements and tests. Using the in-air setup, users will encounter minimal interference from the support.

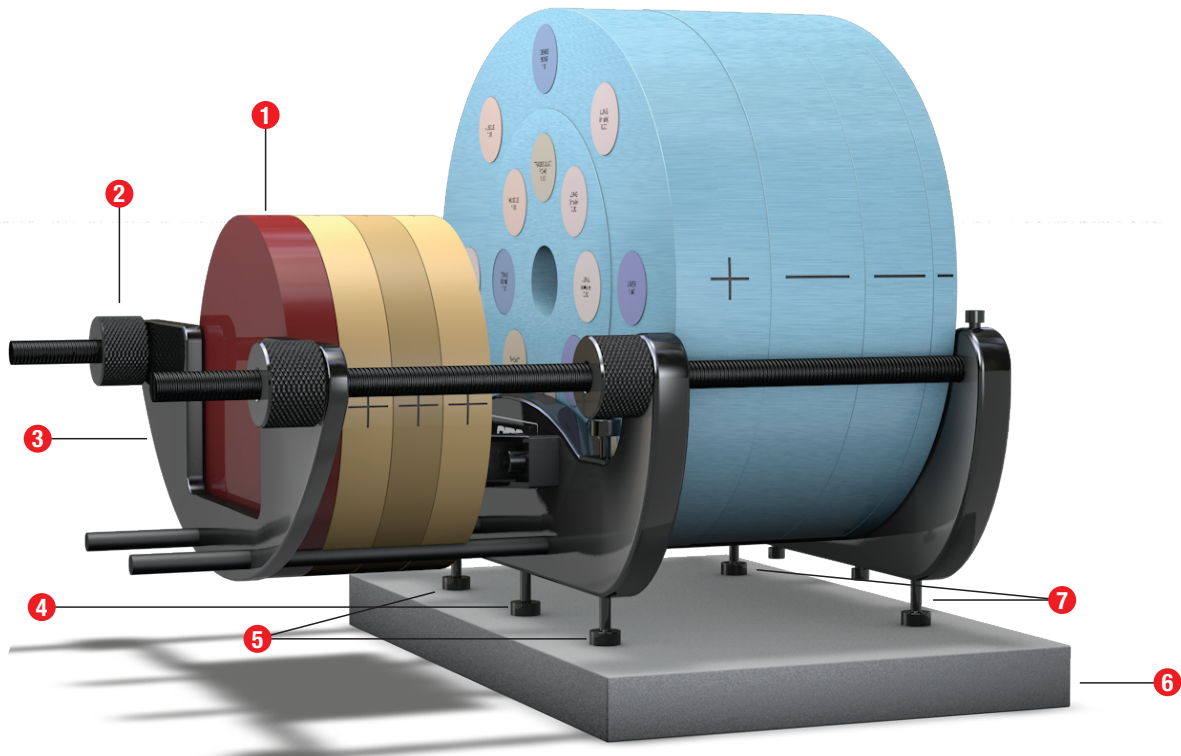

- | | |
|---|--------------------------------------|
| 1 CBCT Image Quality Phantom
Suspended "in air" | 4 Fixed length leveling leg |
| 2 Knurled Knobs
Secure back handle plate
and buffer plate in place | 5 2x Consolidating legs |
| 3 Buffer plate | 6 LINAC Couch |
| | 7 2x Adjustable leveling legs |

Positioning Options

CT IMAGE QUALITY PHANTOM SETUPS

The CT Image Quality Phantom can also be used independently. With the included Holder (062MQA-30), the phantom can be positioned in the “on-the-couch” setup or the “in-air” setup.

“ON-THE-COUCH” SETUP

Level in three point scheme using legs #1, #2 and #4

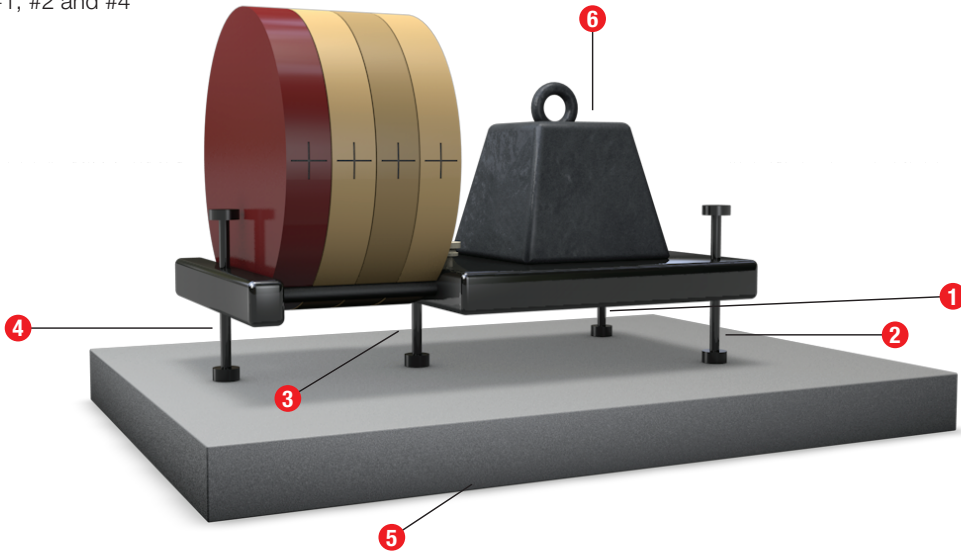

- | | |
|----------|--|
| 1 Leg #1 | 4 Leg# 4 |
| 2 Leg #2 | 5 LINAC Couch |
| 3 Leg #3 | 6 Counterweight (NOT INCLUDED)
Place on the support before leveling |

“IN-AIR” SETUP

Level in three point scheme using legs #1, #2 and #3

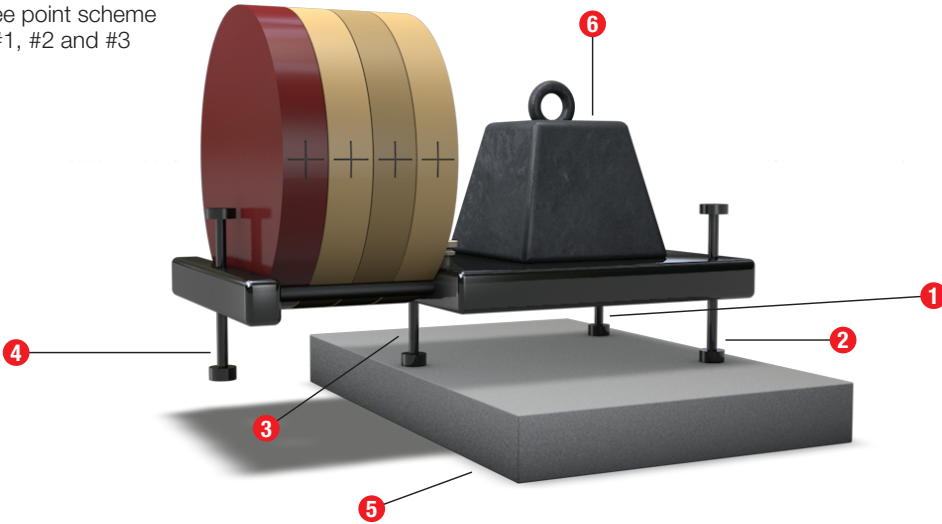

LIMITED WARRANTY

All standard CIRS products and accessories are warranted by CIRS against defects in material and workmanship for a period as specified below. During the warranty period, the manufacturer will repair or, at its option, replace, at no charge, a product containing such defect provided it is returned, transportation prepaid, to the manufacturer. Products repaired in warranty will be returned transportation prepaid.

There are no warranties, expressed or implied, including without limitation any implied warranty of merchantability or fitness, which extend beyond the description on the face hereof. This expressed warranty excludes coverage of, and does not provide relief for, incidental or consequential damages of any kind or nature, including but not limited to loss of use, loss of sales or inconvenience. The exclusive remedy of the purchaser is limited to repair, recalibration, or replacement of the product at manufacturer's option.

This warranty does not apply if the product, as determined by the manufacturer, is defective because of normal wear, accident, misuse, or modification.

Non-Warranty Service

If repairs or replacement not covered by this warranty are required, a repair estimate will be submitted for approval before proceeding with said repair or replacement.

Product	Warranty Period
Non-Standard or customized products	3 months
Training Phantoms and Disposable Products	6 months
Electrical Products and Dynamic Phantoms	12 months
All other standard products	48 months
Plastic Water	60 months



COMPUTERIZED IMAGING REFERENCE SYSTEMS, INC.

900 Asbury Ave
Norfolk, Virginia 23513 USA

Toll Free: 800.617.1177

Tel: 757.855.2765

Fax: 757.857.0523

E-mail admin@cirsinc.com

www.cirsinc.com

Technical Assistance

1.800.617.1177

MODEL 062 SERIES FEATURES

- Modular system integrates three phantoms in one
- Covers geometries for imagers with dimensions up to 40 cm x 40 cm
- Quick positioning and customized loading configurations
- Multiple positioning options, including "in-air" configuration
- High-density plugs available as optional accessory



Computerized Imaging Reference Systems, Inc. has been certified by UL DQS Inc. to **(ISO) 13485:2016**.
Certificate Registration No. 10000905-MP2016.

© 2013 Computerized Imaging Reference Systems, Inc. All rights reserved. All brand names, product names or trademarks belong to their respective holders.

Specifications subject to change without notice.

Publication: 062 PB 121619